

MAMMOUTH

ARTICULÉES : Diesel, Pendulaire, 4x4, roues directrices

DiSTEL



SCHÉMA

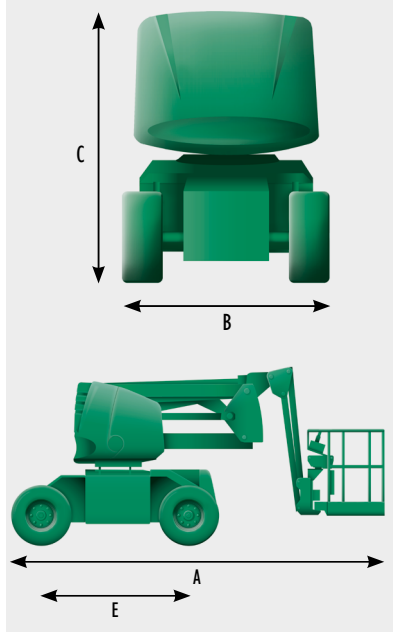

RAPPEL SÉCURITÉ

Art. R. 4323-55 :
Pour conduire une PEMP,
la formation est obligatoire

CONFORME



Kit de retenue nacelle
(voir p. 195)

MANIABILITÉ
4 ROUES
DIRECTRICES

COURBES

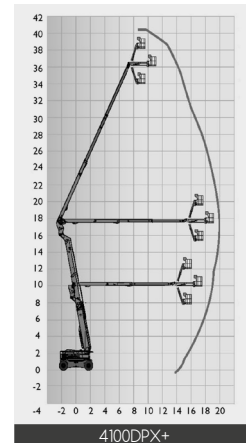
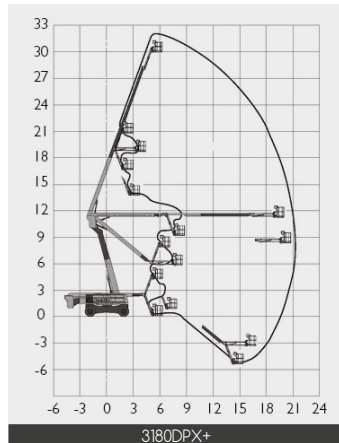
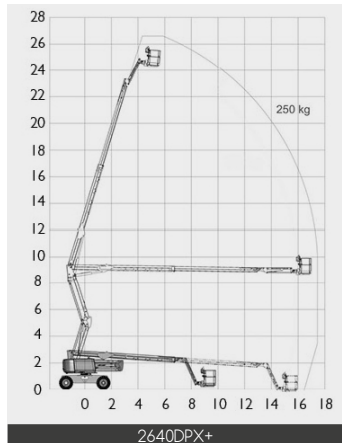
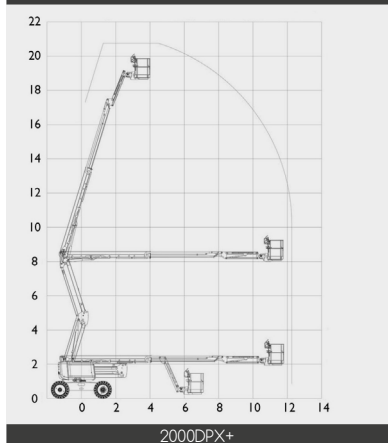

Modèles	2000DPX+	2640DPX+	3180DPX+	4100DPX+
Hauteur de travail	20m60	26m40	31m80	41m50
Hauteur de plancher	18m60	24m40	29m80	39m50
Poids total	9 600 kg	15 500 kg	20 100 kg	23 900 kg
Charge admissible dans la plate-forme	230 kg (2+1)	250 kg (2+1)	250 kg (2+1)	230 kg (2+1)
Dimensions de la plate-forme	1m83 x 0m80	2m44 x 0m91	2m44 x 0m91	2m44 x 0m91
Déport maximum - axe tourelle	12m20	17m50	21m60	20m10
A/B. Longueur/Largeur hors tout	8m80/2m42	11m80/2m48	11m70/2m53	13m10/2m53
Largeur essieux déployés	---	---	3m30	3m30
C. Hauteur repliée	2m93	2m97	2m80	2m99
E. Empattement	2m45	2m80	3m50	3m50
Déport arrière	0m15	0m76	3m30	3m88



*Existe avec barre anti-écrasement